

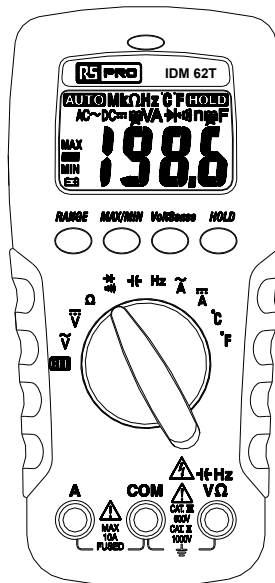

Instruction Manual
IDM 61/62T
Digital Multimeter

EN DE ES IT FR



⚠ Safety Information

Read and understand this Instruction Manual completely before using this instrument. Failure to observe the warnings and cautions in this Instruction Manual may result in injury or death, or damage to the instrument and other equipment or property.

If this instrument is used in a manner not specified in these instructions, the protection provided by the instrument may be impaired.

⚠ WARNING

- Examine the instrument and probes before use. Do not use the instrument if it is wet or damaged.
- When using test leads or probes, keep your fingers behind the finger guards.
- Remove the test lead from the instrument before opening the battery cover or instrument case.
- Always use the correct terminals, switch position and range for measurements.
- Never attempt a voltage measurement with the test leads inserted into the A input terminals.
- Verify the instrument is operating correctly by measuring a known voltage before use. If in doubt, have the instrument serviced.
- Do not apply more than the rated voltage, as marked on the instrument, between terminals or between any terminal and earth ground.
- Do not attempt a current measurement when the open-circuit voltage is above the fuse protection rating.
- Only replace a blown fuse with the correct type and rating as specified in this Instruction Manual.
- Use caution when measuring voltages above 30 Vac rms or 60 Vdc. These voltages pose a shock hazard.
- To avoid incorrect readings that can lead to electric shock, replace the battery as soon as low battery indicator  appears in the display.
- Disconnect the circuit power and discharge all high-voltage capacitors before making resistance, current, continuity, diode or capacitance measurements.
- Do not use the instrument in a Hazardous Area or around explosive gasses or vapours.
- Wear suitable Personal Protective Equipment when working around or near hazardous Live conductors which could be accessible.

Measuring AC/DC Voltage and Frequency

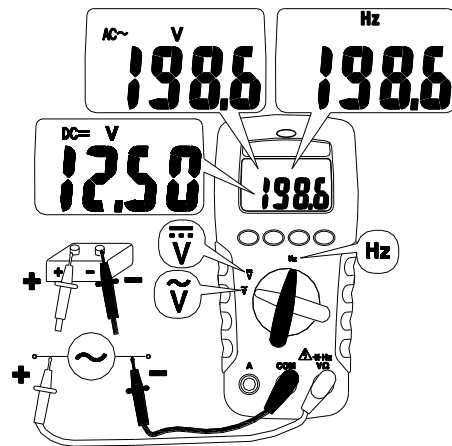

Continuity and Diode Test

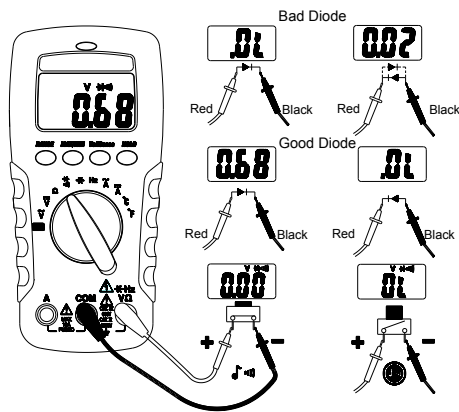

Resistance and Capacitance Measurement
(Capacitance for 62T only)

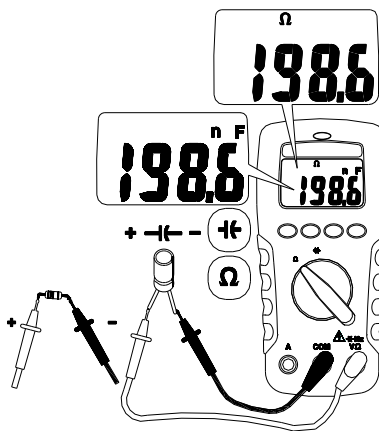

Note – To improve the measurement accuracy of a small value capacitor, record the reading with the test leads open circuit, then subtract the residual capacitance of the Instrument and leads from the final measurement.

$$C_{\text{UNKNOWN}} = C_{\text{MEASUREMENT}} - C_{\text{RESIDUAL}}$$

MIN MAX Record (For 62T only)

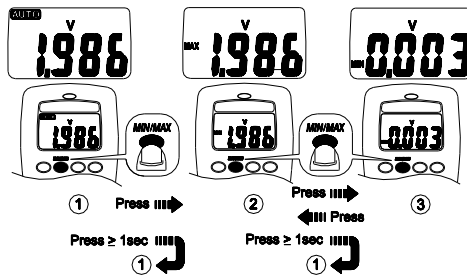

Measuring DC / AC Current (For 62T only)

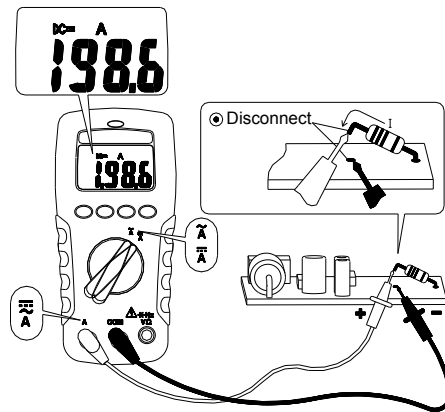

Temperature °C, °F

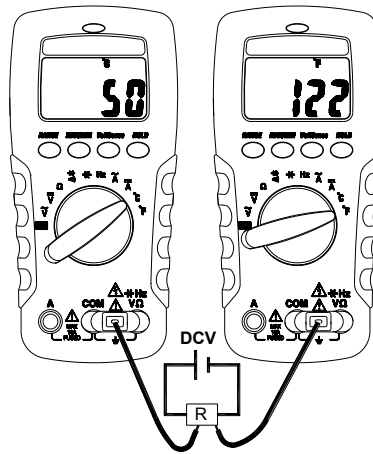

Display Hold

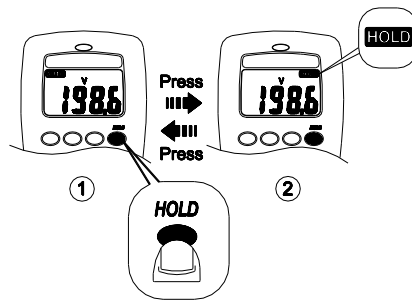

Manual Ranging and Auto Ranging

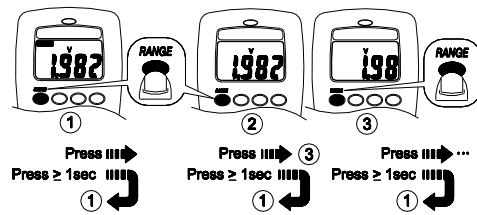

Auto Power-off (Battery Saver)

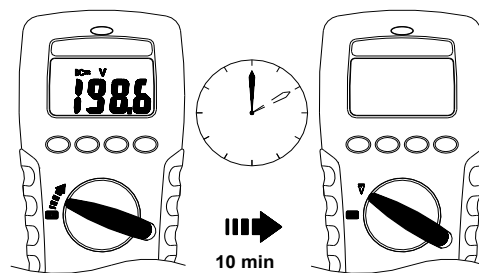

Disable Auto Power-off

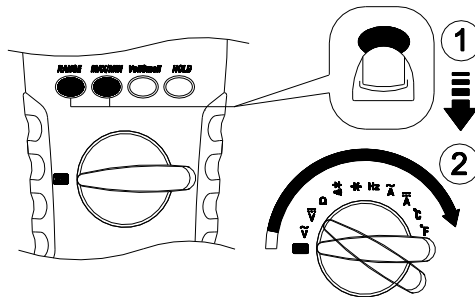

Non-Contact Voltage Sensing (VoltSense)

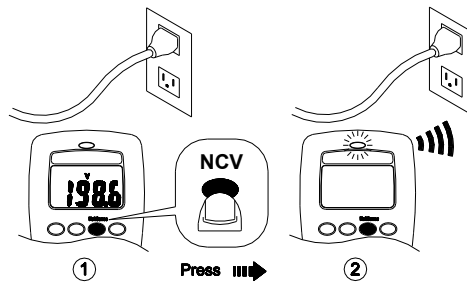

1. The VoltSense function will operate irrespective of the position of the function rotary switch, including the OFF position.
2. Remove the test leads from the instrument as they are not used for the VoltSense test.
3. Press and hold the VoltSense button. The LCD display will go blank, a tone will sound and the red LED will illuminate momentarily to confirm the instrument is operational.
4. Hold the Volt sense button down and move the instrument over the area where detection is required. The buzzer will sound and the LED will illuminate when a live conductor is detected. Release the VoltSense button to return to normal operation.

Fuse Replacement (For 62T only)

⚠ WARNING

Disconnect the test leads from the circuit and the instrument before removing the rear cover.

⚠ Caution

Use only a replacement fuse of the type and rating given in the specifications.

Refer to the following figure to replace the fuse :

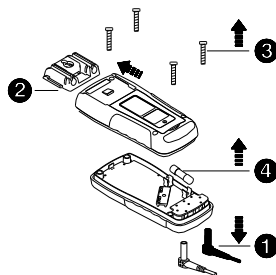

Battery Replacement

When the low battery indicator "⚡" appears on the LCD, replace the batteries with the type given in the specifications.

⚠ WARNING

Disconnect the test leads from the circuit and the instrument before removing the battery cover.

Refer to the following figure to replace the batteries :

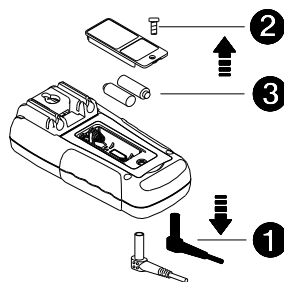

Specifications

General Specifications

Display : 2000 counts.

Polarity Indication : Automatic, positive implied, negative indicated.

Overrange Indication : "OL" or "-OL".

Batteries Life : 250 hours approx with Alkaline cells.

Low Batteries Indication : "~" is displayed when the battery voltage drops below the minimum operating voltage.

Auto Power Off : Approx 10 minutes after last operation.

Storage Temperature : -20 to 60°C (-4°F to 140°F) @ 0 to 80% R.H. with the battery removed from the instrument.

Operating Ambient : Non-condensating, $\leq 10^{\circ}\text{C}$ (50°F); 11 to 30°C (51.8°F to 86°F) @ $\leq 80\%$ R.H.; 31 to 40°C (87.8°F to 104°F) @ $\leq 75\%$ R.H.; 41 to 50°C (105.8°F to 122°F) @ $\leq 45\%$ R.H.

Measurement Category (Installation Category) per IEC 61010-1:2001: **V/Q**: CAT.III. 600V, CAT.II. 1000V.

A: CAT.III. 600V (for 62T only)
Pollution Degree 2

Measurement Category I is for measurements performed on circuits not directly connected to mains. Examples include: Measurements on battery powered equipment and specially protected (internal) mains-derived circuits.

Measurement Category II is for measurements on circuits directly connected to the low voltage installation. Examples include: Household appliances, portable tools and similar equipment.

Measurement Category III is for measurements performed in the building installation. Examples include measurements on distribution boards, junction boxes, socket-outlets and wiring and cables in the fixed installation.

Measurement Category IV is for measurements performed at the source of the low-voltage installation. Examples include measurements on primary over current protection devices and electricity meters.

Temperature Coefficient : 0.27 x Spec. Accy / °C <18°C or >28°C;
(0.15 x Spec. Accy / °F, < 64.4°F or > 82.4°F).

Power Requirements : Qty. 2 x 1.5V Alkaline type AA batteries.

Fuse (For 62T only) : 10mmx38 mm 10Amp 600V ac/dc HBC,
Little fuse KLKD10 or equivalent.

Dimensions (W x H x D) : 74mm x 156mm x 44mm

Accessories : Battery (installed), Test leads and user manual.

Measurement rate : Sampling rate 2 times per second nominal.

Altitude : 6561.7 ft (2000m)

Safety : Complies with EN61010-1:2001, UL61010-1:2001 and
IEC 61010-1:2001.

Weight : (320g) including battery.

Electrical Specifications

Accuracy is \pm (% reading + number of digits) at 23°C \pm 5°C < 80%RH.

DC / AC Volts

Range	AC Accuracy
200.0mV *	Unspecified
2.000V *	$\pm(1.5\%+5\text{dgt})$ 50Hz ~ 300Hz
20.00V ~ 200.0V *	$\pm(1.5\%+5\text{dgt})$ 50Hz ~ 500Hz *
750V AC / 1000V DC	

DC Accuracy : $\pm(0.5\% + 2\text{dgt})$

Over voltage protection : 1000V DC or 750 V ACrms.

Input Impedance : 10M Ω // less than 100pF.

*** CMRR / NMRR : (Common Mode Rejection Ratio)
(Normal Mode Rejection Ratio)**

V_{AC} : CMRR > 60dB at DC, 50Hz / 60Hz

V_{DC} : CMRR > 100dB at DC, 50Hz / 60Hz

NMRR > 50dB at DC, 50Hz / 60Hz

AC Conversion Type : Average sensing rms indication.

AC conversions are ac-coupled, true rms responding, calibrated to the
sine wave input.

* The minimum LCD reading is 1400 count in Auto Ranging Mode.

Crest Factor : C.F. = Peak / Rms

+ 1.5% addition error for C.F. from 1.4 to 3

+ 3% addition error for C.F. from 3 to 4

DC / AC Current (For 62T only)

Range	DC Accuracy	AC Accuracy	Voltage Burden
2.000A	$\pm(1.0\% + 3 \text{ dgt})$	$\pm(1.5\% + 5 \text{ dgt})$ 50Hz ~ 500Hz *	2V max
10.00A **			

Overload Protection :

A input : 10A (600V) fast blow fuse

* **AC Conversion Type** : Conversion type and additional specification are same as DC/AC Voltage.**** Ampere Testing Duty Ratio Table**

Ampere	Testing Time	Rest Time
10A	4min	10min
9A	5min	10min
8A	7min	10min
7A	10min	10min
6A	Continually	N/A

Resistance

Range	Accuracy	Voltage Burden
200.0 ~ 200.0K Ω **	$\pm(0.7\% + 3 \text{ dgt})$	2V max
2.000M Ω **	$\pm(1.0\% + 3 \text{ dgt})$	
20.00M Ω *	$\pm(1.5\% + 3 \text{ dgt})$	

Open circuit Voltage : -1.3V approx.

* <100 dgt rolling.

Diode Check and Continuity

Range	Resolution	Accuracy
→	10 mV	$\pm(1.5\% + 5 \text{ dgt})^*$

* For 0.4V ~ 0.8V

Max. Test Current : 1.5mA

Max. Open Circuit Voltage : 2V

Overload Protection : 600V rms.

Frequency (For 62T only)

Range	Sensitivity	Accuracy
2000Hz ~200.0KHz	>1.5 Vac rms, <5 Vac rms	Frequency : 0.01%±1digit
2.000MHz ~ 20.00MHz	>2 Vac rms, <5 Vac rms	

Overload Protection : 600V rms.

Minimum pulse width : >25 ns

Duty cycle limits : >30% and <70%

Capacitance (For 62T only)

Range	Accuracy	Overload Protection
2.000nF ~ 200.0µF	$\pm(1.9\% + 8 \text{ dgt})$	600V rms
2.000mF *		

* < 10 dgt of reading rolling.

Temperature (°C) (For 62T only)

Temperature	Accuracy	Overload Protection
-20°C ~ 0°C	$\pm(2\% + 4^\circ\text{C})$	600V rms
1°C ~ 100°C	$\pm(1\% + 3^\circ\text{C})$	
101°C ~ 500°C	$\pm(2\% + 3^\circ\text{C})$	
501°C ~ 800°C	$\pm(3\% + 2^\circ\text{C})$	

Temperature (°F) (For 62T only)		
Temperature	Accuracy	Overload Protection
-4°F ~ 32°F	±(2% + 8°F)	600V rms
33°F ~ 212°F	±(1% + 6°F)	
213°F ~ 932°F	±(2% + 6°F)	
933°F ~ 1472°F	±(3% + 4°F)	

Limited Warranty

This instrument is warranted to the original purchaser against defects in material and workmanship for 3 years from the date of purchase. During this warranty period, RS Components will, at its option, replace or repair the defective unit, subject to verification of the defect or malfunction. This warranty does not cover disposable batteries, or damage from abuse, neglect, accident, unauthorized repair, alteration, contamination, or abnormal conditions of operation or handling. Any implied warranties arising out of the sale of this product, including but not limited to implied warranties of merchantability and fitness for a particular purpose, are limited to the above. RS Components shall not be liable for loss of use of the instrument or other incidental or consequential damages, expenses, or economic loss, or for any claim or claims for such damage, expense or economic loss. Some states or countries laws vary, so the above limitations or exclusions may not apply to you. For full terms and conditions, refer to the current RS Catalogue.

Africa**RS Components SA**

P.O. Box 12182, Vorna Valley, 1686
20 Indianapolis Street, Kyalami Business Park,
Kyalami, Midrand
South Africa

www.rs-components.com

Asia**RS Components Pte Ltd.**

31 Tech Park Crescent
Singapore 638040

www.rs-components.com

China**RS Components Ltd.**

Suite 23 A-C , East Sea Business Centre
Phase 2 , No. 618 Yan'an Eastern Road
Shanghai, 200001
China

www.rs-components.com

Europe**RS Components Ltd.**

PO Box 99, Corby,
Northants. NN17 9RS
United Kingdom

www.rs-components.com

Japan**RS Components Ltd.**

West Tower (12th Floor),
Yokohama Business Park, 134 Godocho, Hodogaya,
Yokohama, Kanagawa 240-0005
Japan

www.rs-components.com

U.S.A**Allied Electronics**

7151 Jack Newell Blvd. S.
Fort Worth, Texas 76118
U.S.A.

www.alliedelec.com

South America**RS Componentes Limitada**

Av. Pdte. Eduardo Frei M. 6001-71
Centro Empresas El Cortijo
Conchalí, Santiago, Chile

www.rs-components.com